

**NOTES:**

1. PANEL VERTICAL AND HORIZONTAL JOINT SPACING SHOULD BE 5/16" TYPICAL.
2. EPDM GASKET **MUST** BE INSTALLED CONTINUOUSLY ON ALL SUBFRAMING.

SCALE: 6"=1'-0"

Ref.:  
**Typical Butt  
 Joint Detail**

Date: 4/6/2019



**KØL HIGH DENSITY  
 FIBRE CEMENT FACADE PANELS**  
 KOLFACADE.COM

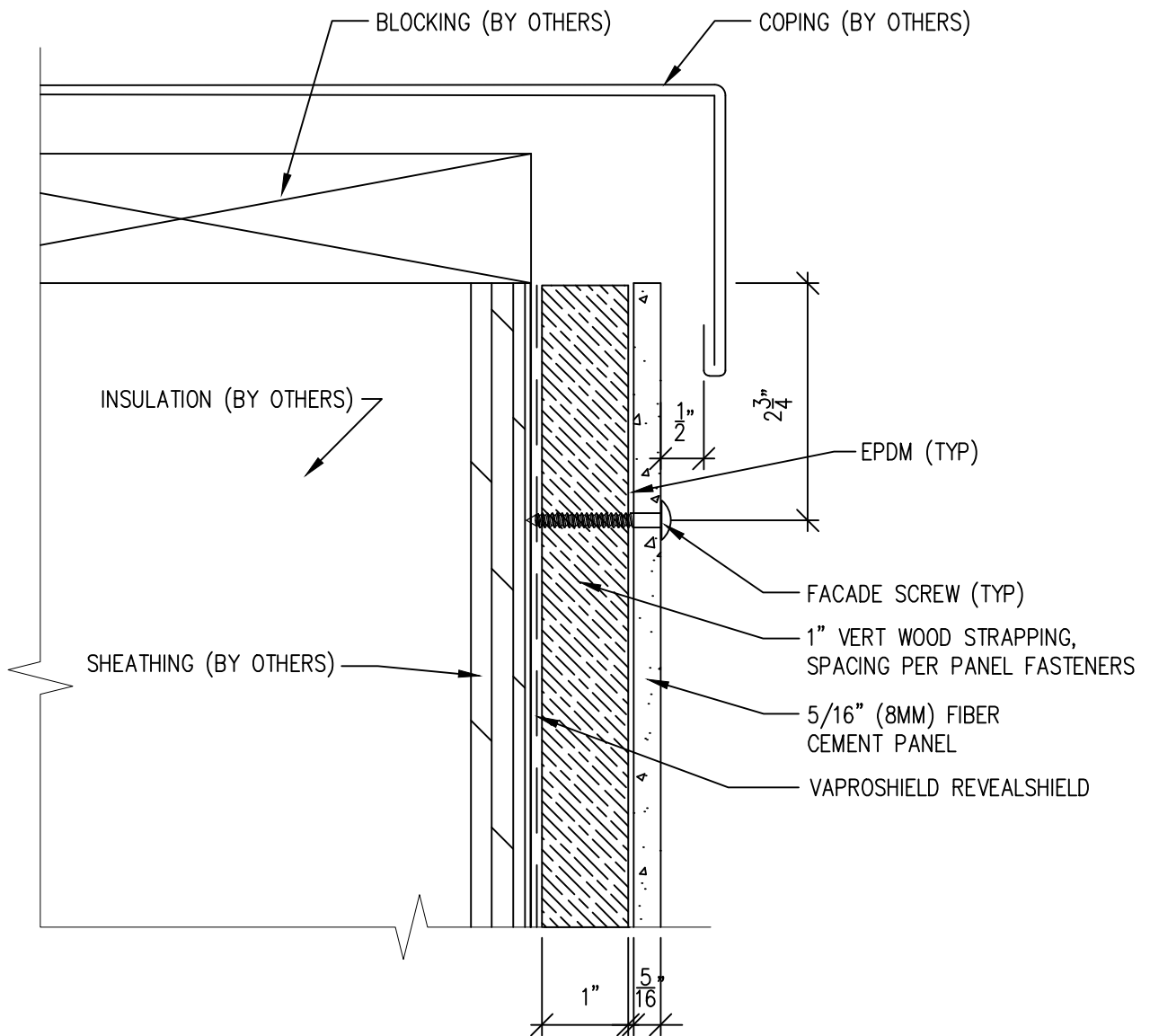

**NOTES:**

1. PANEL VERTICAL AND HORIZONTAL JOINT SPACING SHOULD BE 5/16" TYPICAL.
2. EPDM GASKET **MUST** BE INSTALLED CONTINUOUSLY ON ALL SUBFRAMING.

SCALE: 6"=1'-0"

Ref.:  
**Typical Coping  
 Panel Detail**

Date: 4/6/2019



KØL HIGH DENSITY  
 FIBRE CEMENT FACADE PANELS  
 KOLFACADE.COM

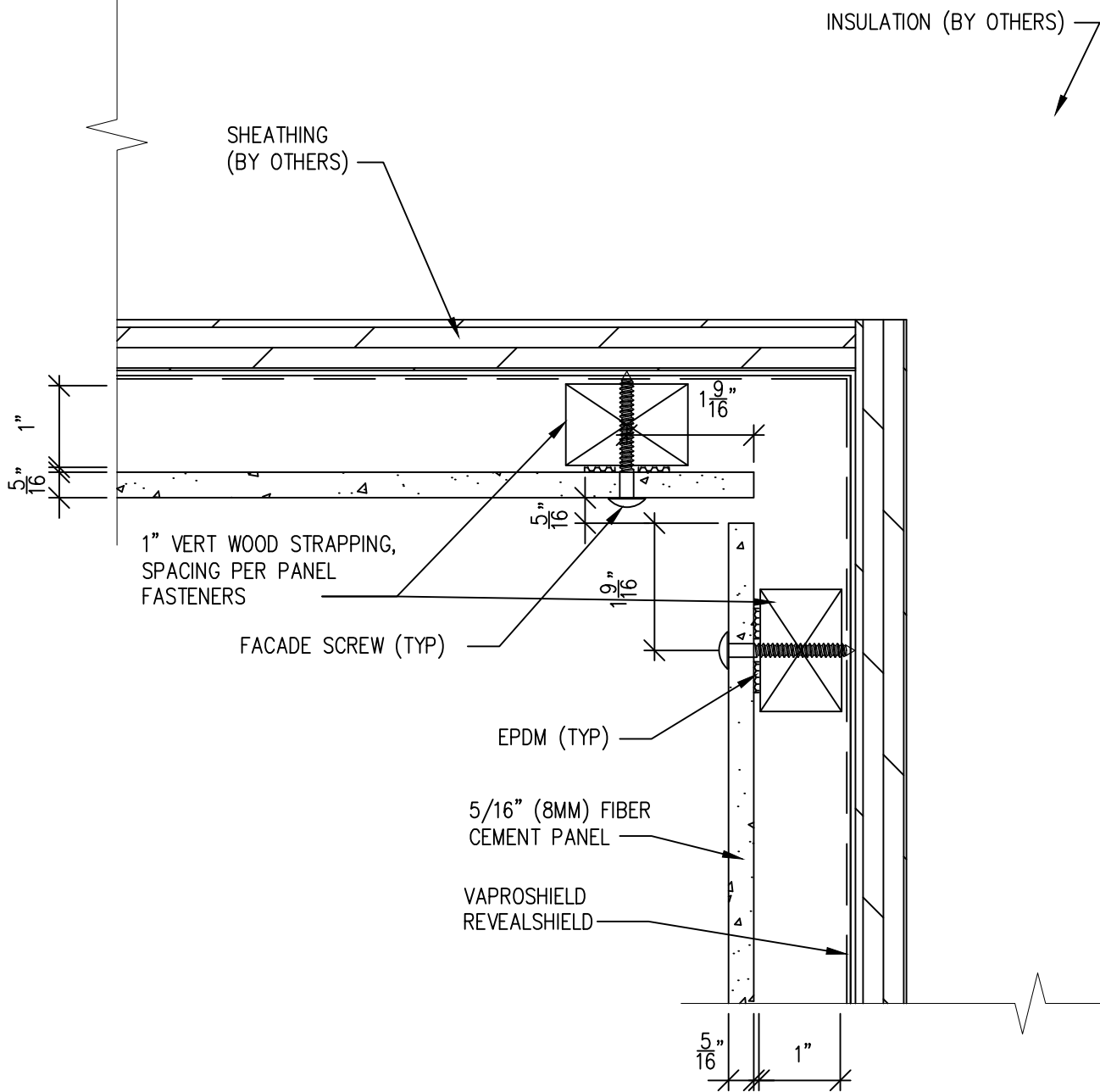

**NOTES:**

1. PANEL VERTICAL AND HORIZONTAL JOINT SPACING SHOULD BE 5/16" TYPICAL.
2. EPDM GASKET **MUST** BE INSTALLED CONTINUOUSLY ON ALL SUBFRAMING.

SCALE: 6"=1'-0"

Ref.:  
**Typical Inside  
 Corner Detail**

Date: 4/6/2019



**KØL HIGH DENSITY  
 FIBRE CEMENT FACADE PANELS**  
 KOLFACADE.COM

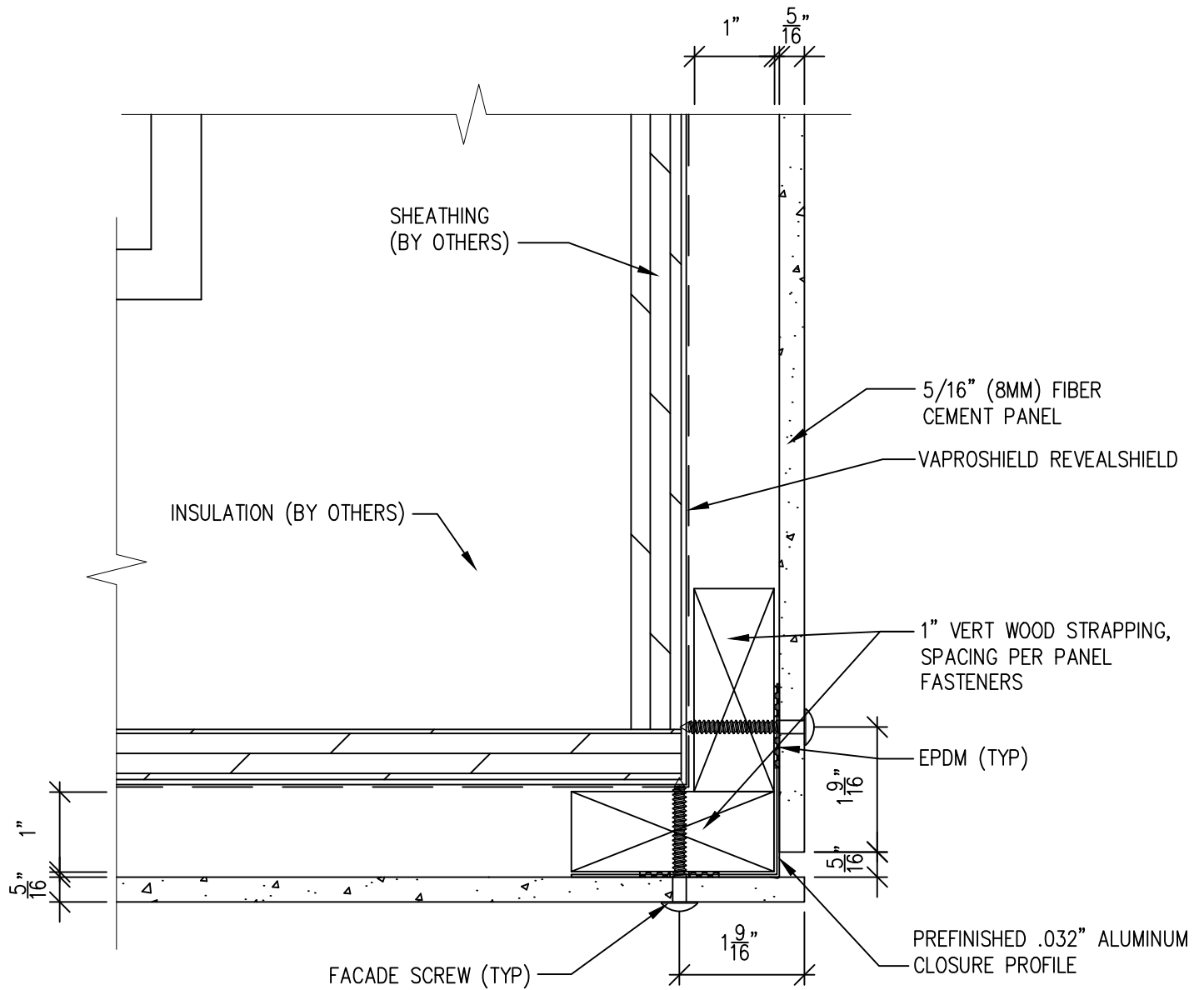

**NOTES:**

1. PANEL VERTICAL AND HORIZONTAL JOINT SPACING SHOULD BE 5/16" TYPICAL.
2. EPDM GASKET **MUST** BE INSTALLED CONTINUOUSLY ON ALL SUBFRAMING.

SCALE: 6"=1'-0"



KØL HIGH DENSITY  
 FIBRE CEMENT FACADE PANELS  
 KOLFACADE.COM

Ref.:  
 Typical Outside  
 Corner Detail

Date: 4/6/2019

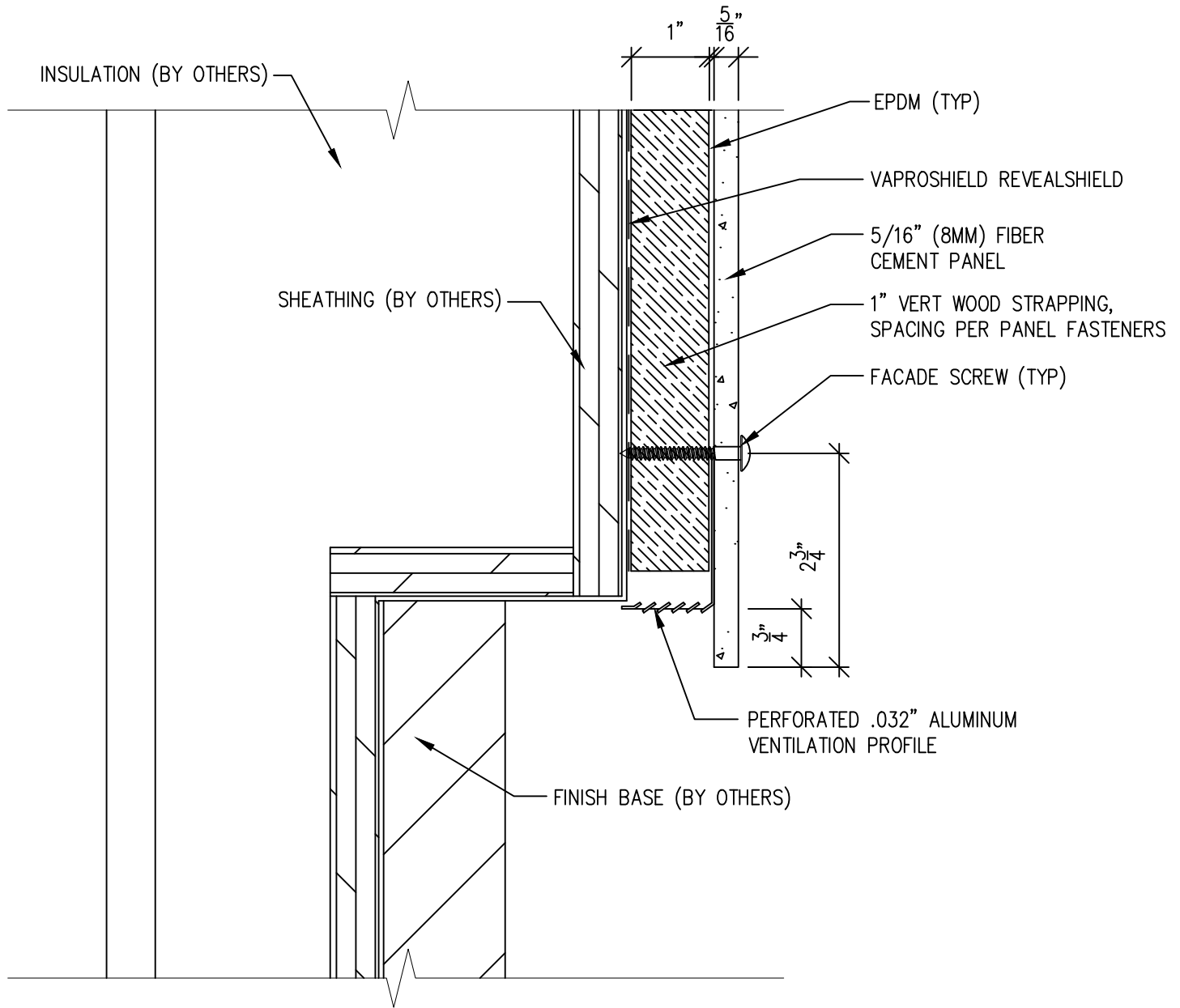

**NOTES:**

1. PANEL VERTICAL AND HORIZONTAL JOINT SPACING SHOULD BE 5/16" TYPICAL.
2. EPDM GASKET **MUST** BE INSTALLED CONTINUOUSLY ON ALL SUBFRAMING.

SCALE: 6"=1'-0"

Ref.:  
**Typical Panel  
 Base Detail**

Date: 4/6/2019



KØL HIGH DENSITY  
 FIBRE CEMENT FACADE PANELS  
 KOLFACADE.COM

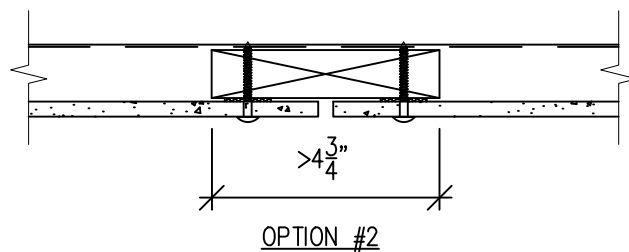
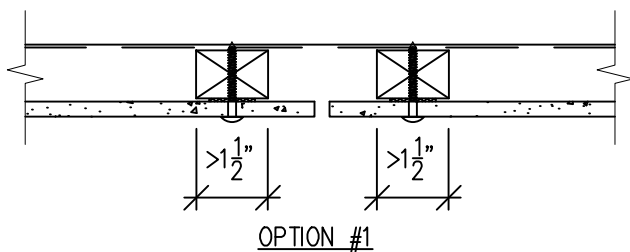
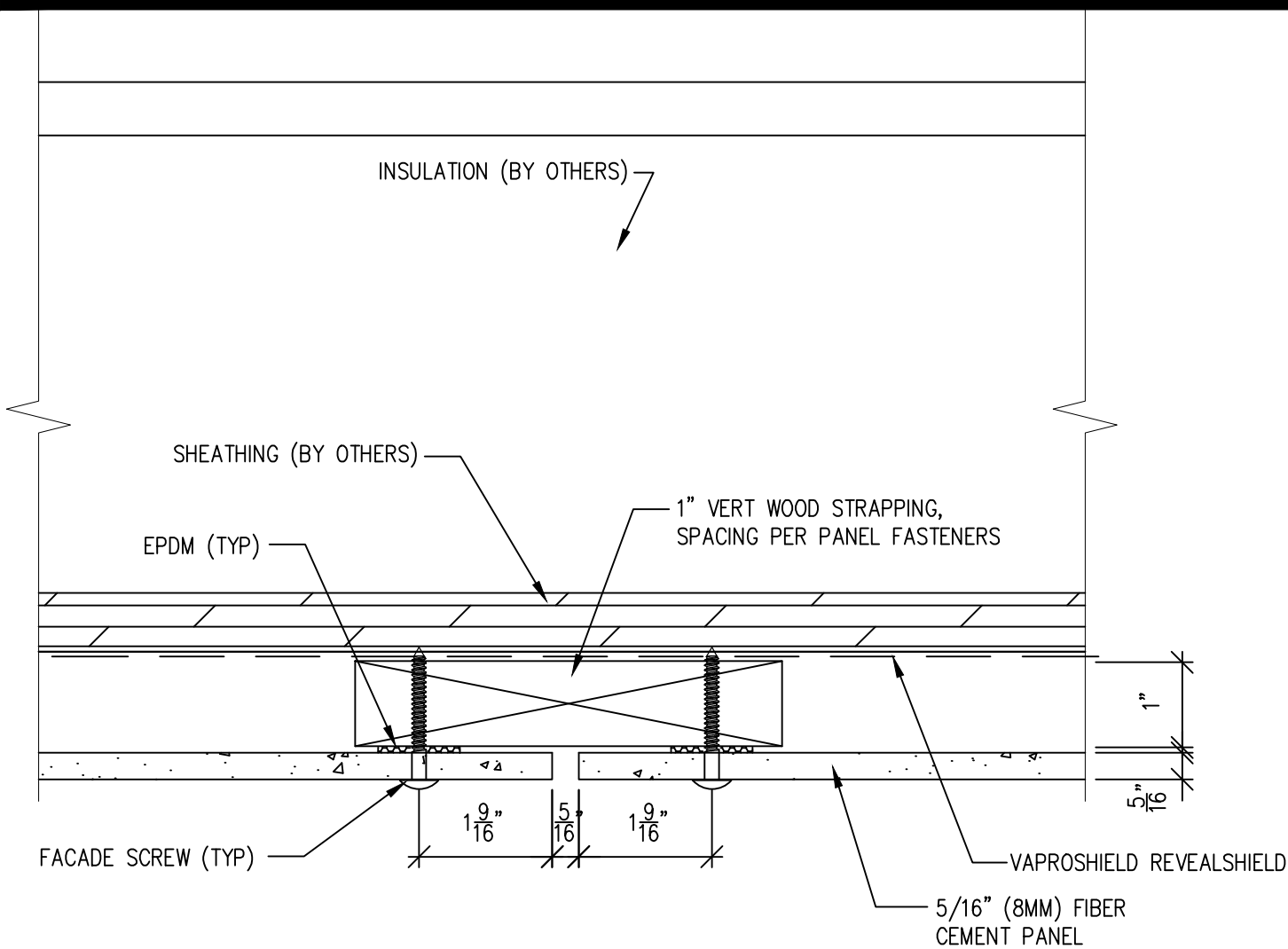

NOTES:

1. PANEL VERTICAL AND HORIZONTAL JOINT SPACING SHOULD BE 5/16" TYPICAL.
2. EPDM GASKET **MUST** BE INSTALLED CONTINUOUSLY ON ALL SUBFRAMING.

SCALE: 6"=1'-0"



KØL HIGH DENSITY  
FIBRE CEMENT FACADE PANELS  
KOLFACADE.COM

Ref.:  
Typical Vertical  
Panel Joint Detail

Date: 4/6/2019

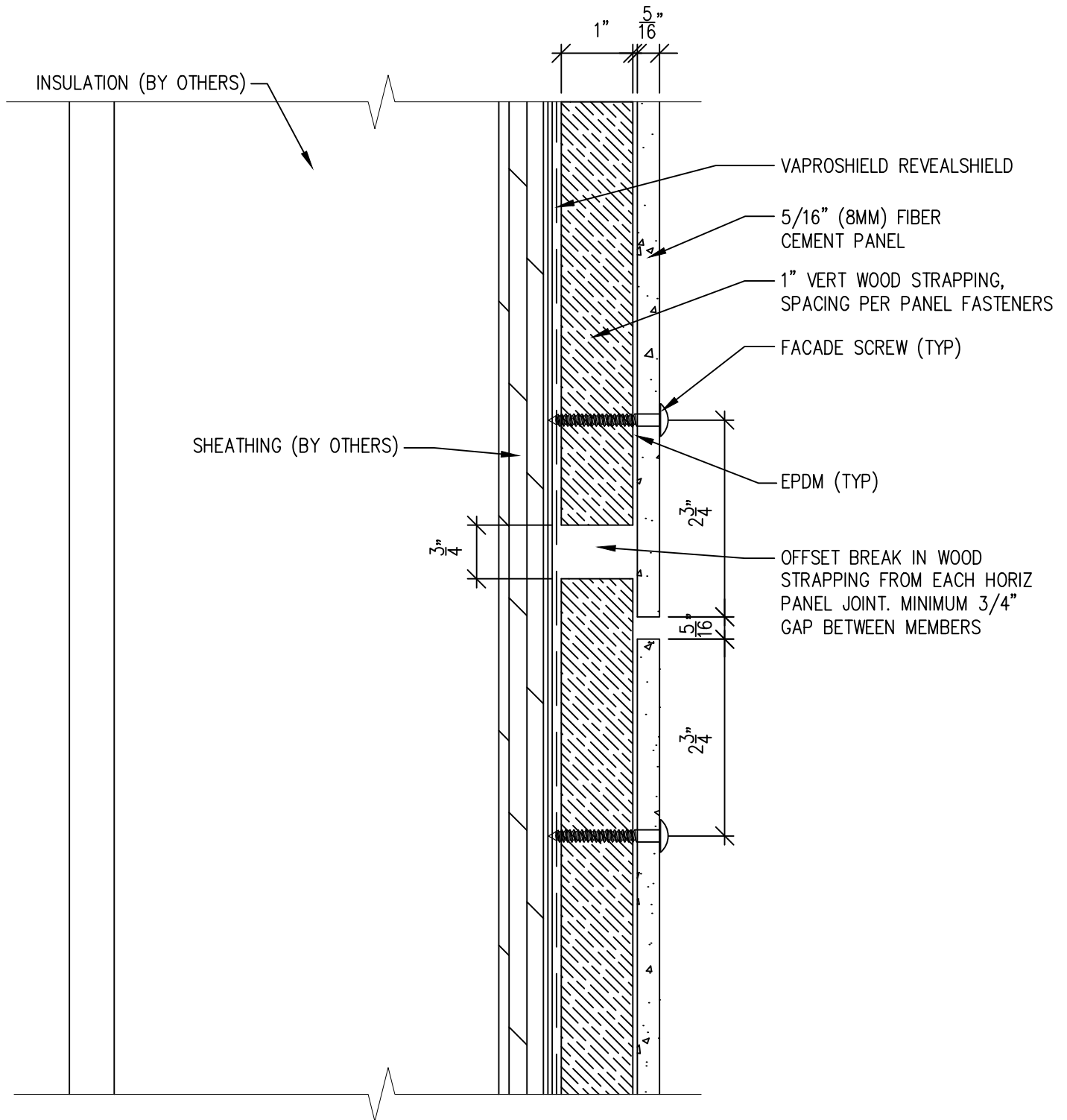

**NOTES:**

1. PANEL VERTICAL AND HORIZONTAL JOINT SPACING SHOULD BE 5/16" TYPICAL.
2. EPDM GASKET **MUST** BE INSTALLED CONTINUOUSLY ON ALL SUBFRAMING.

SCALE: 6"=1'-0"

Ref.:  
**Typical Horizontal  
 Panel Joint Detail**

Date: 4/6/2019



**KØL HIGH DENSITY  
 FIBRE CEMENT FACADE PANELS**  
 KOLFACADE.COM

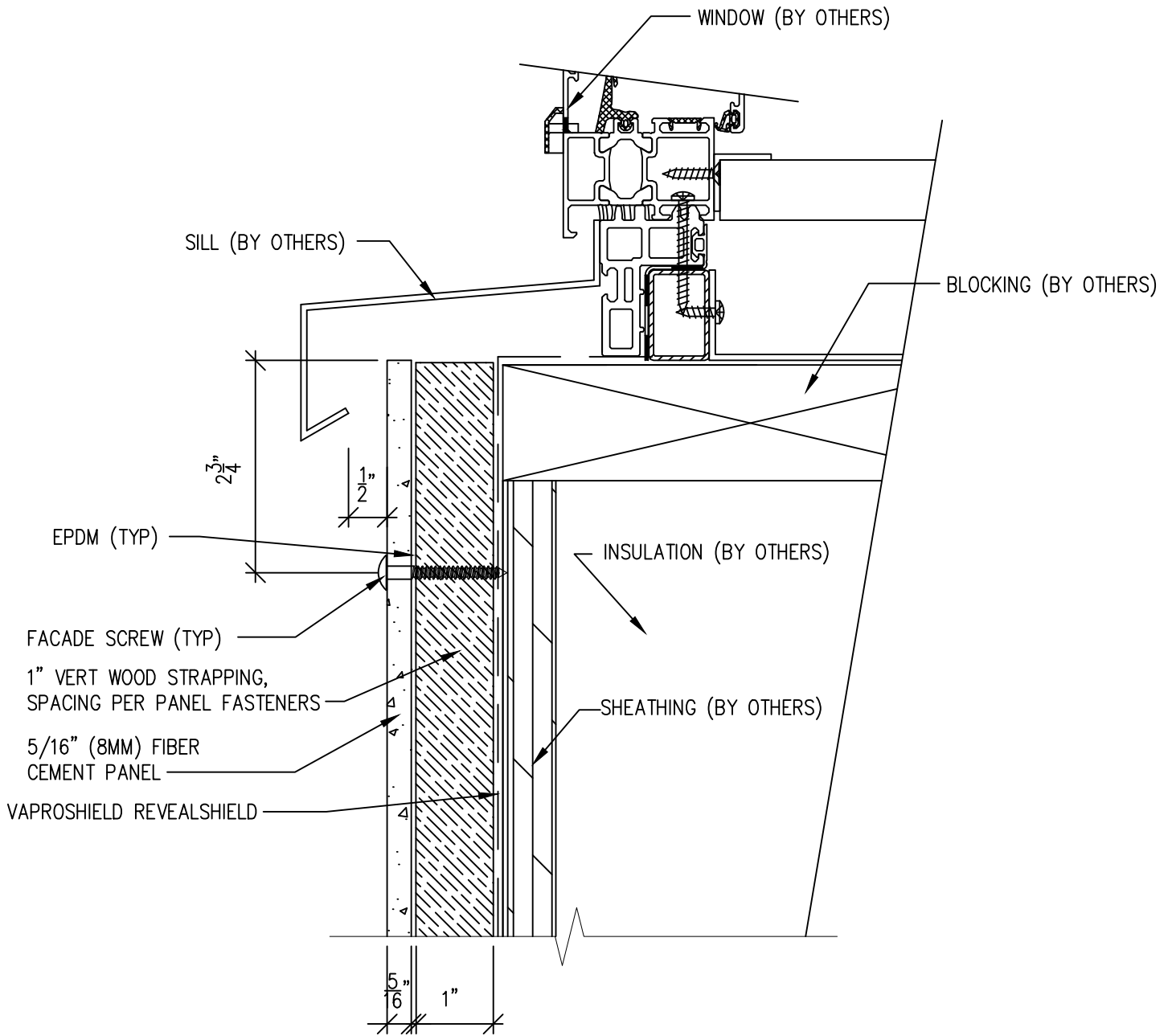

NOTES:

1. PANEL VERTICAL AND HORIZONTAL JOINT SPACING SHOULD BE  $5/16$ " TYPICAL.
2. EPDM GASKET **MUST** BE INSTALLED CONTINUOUSLY ON ALL SUBFRAMING.

SCALE: 6"=1'-0"

Ref.:  
Typical Window  
Sill Detail

Date: 4/6/2019

**KØL**

KØL HIGH DENSITY  
FIBRE CEMENT FACADE PANELS

KOLFACADE.COM



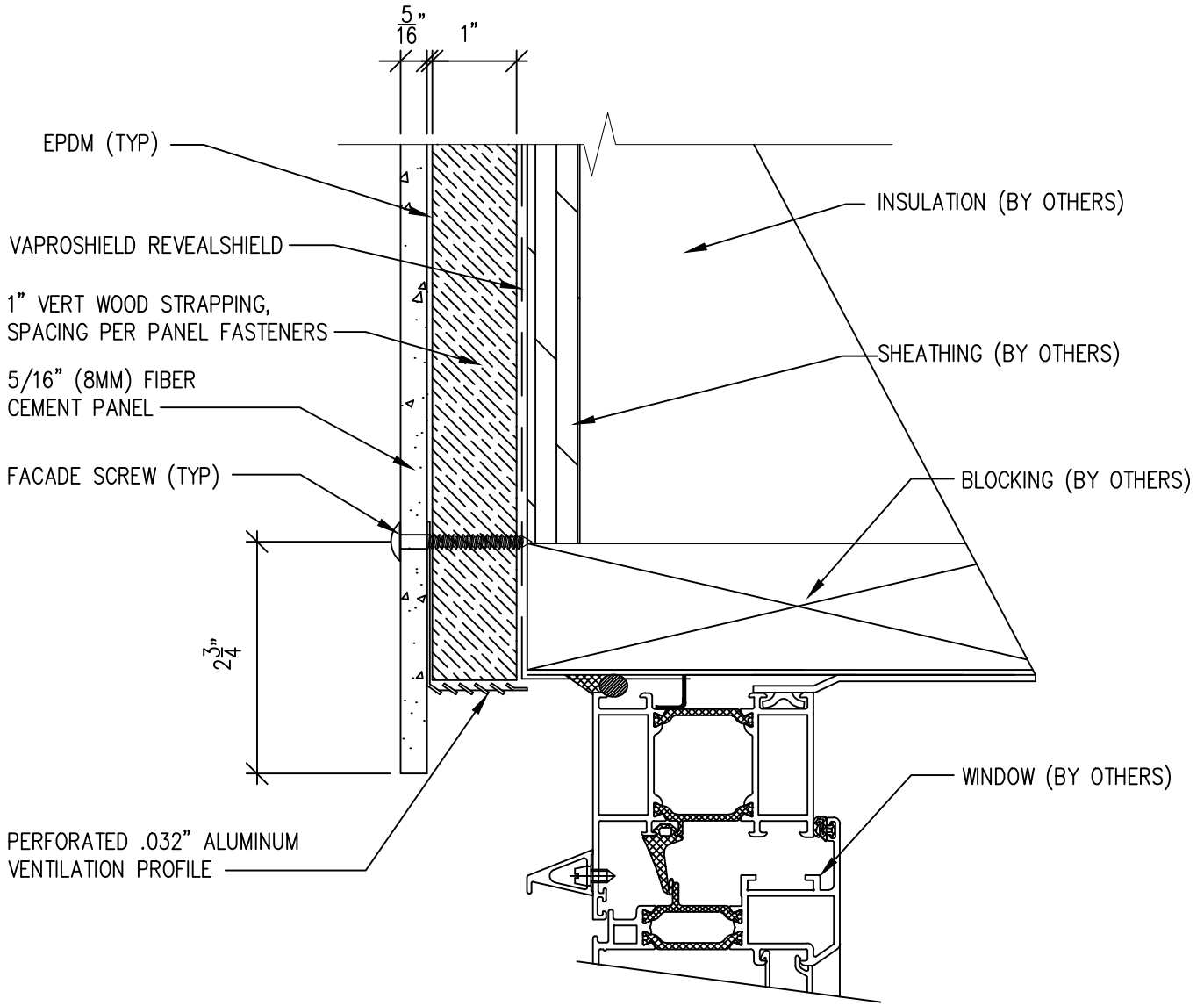

**NOTES:**

1. PANEL VERTICAL AND HORIZONTAL JOINT SPACING SHOULD BE 5/16" TYPICAL.
2. EPDM GASKET **MUST** BE INSTALLED CONTINUOUSLY ON ALL SUBFRAMING.

SCALE: 6"=1'-0"



KØL HIGH DENSITY  
 FIBRE CEMENT FACADE PANELS  
 KOLFACADE.COM

Ref.:  
 Typical Window  
 Head Detail

Date: 4/6/2019

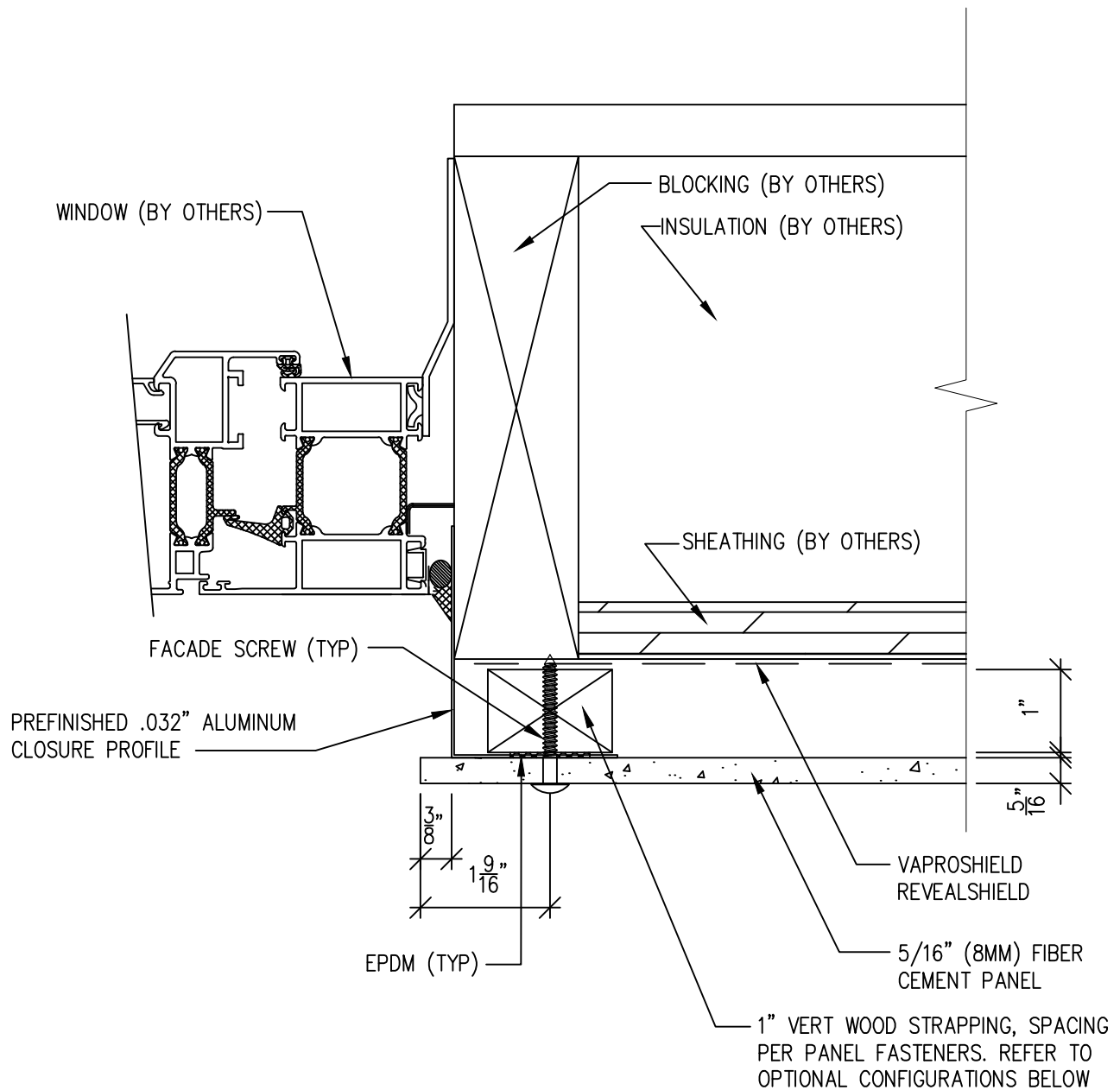

**NOTES:**

1. PANEL VERTICAL AND HORIZONTAL JOINT SPACING SHOULD BE 5/16" TYPICAL.
2. EPDM GASKET **MUST** BE INSTALLED CONTINUOUSLY ON ALL SUBFRAMING.

SCALE: 6"=1'-0"

Ref.:

Typical Window  
Jamb Detail

Date: 4/6/2019

**KØL**

KØL HIGH DENSITY  
FIBRE CEMENT FACADE PANELS

KOLFACADE.COM

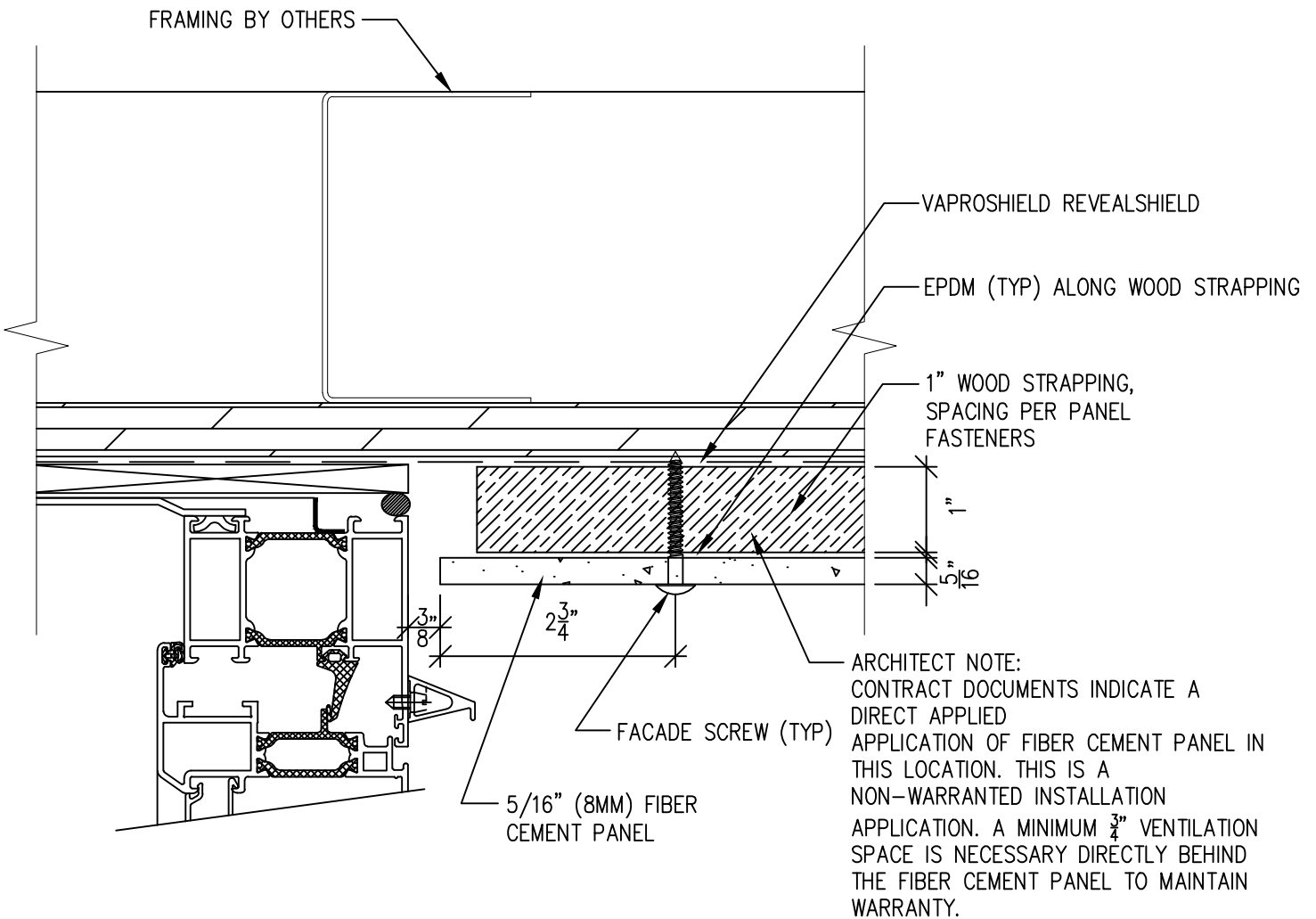

NOTES:

1. PANEL VERTICAL AND HORIZONTAL JOINT SPACING SHOULD BE 5/16" TYPICAL.
2. EPDM GASKET **MUST** BE INSTALLED CONTINUOUSLY ON ALL SUBFRAMING.

SCALE: 6"=1'-0"

Ref.:

Typical Window  
Jamb Detail

Date: 4/6/2019

KØL

KØL HIGH DENSITY  
FIBRE CEMENT FACADE PANELS

KOLFACADE.COM

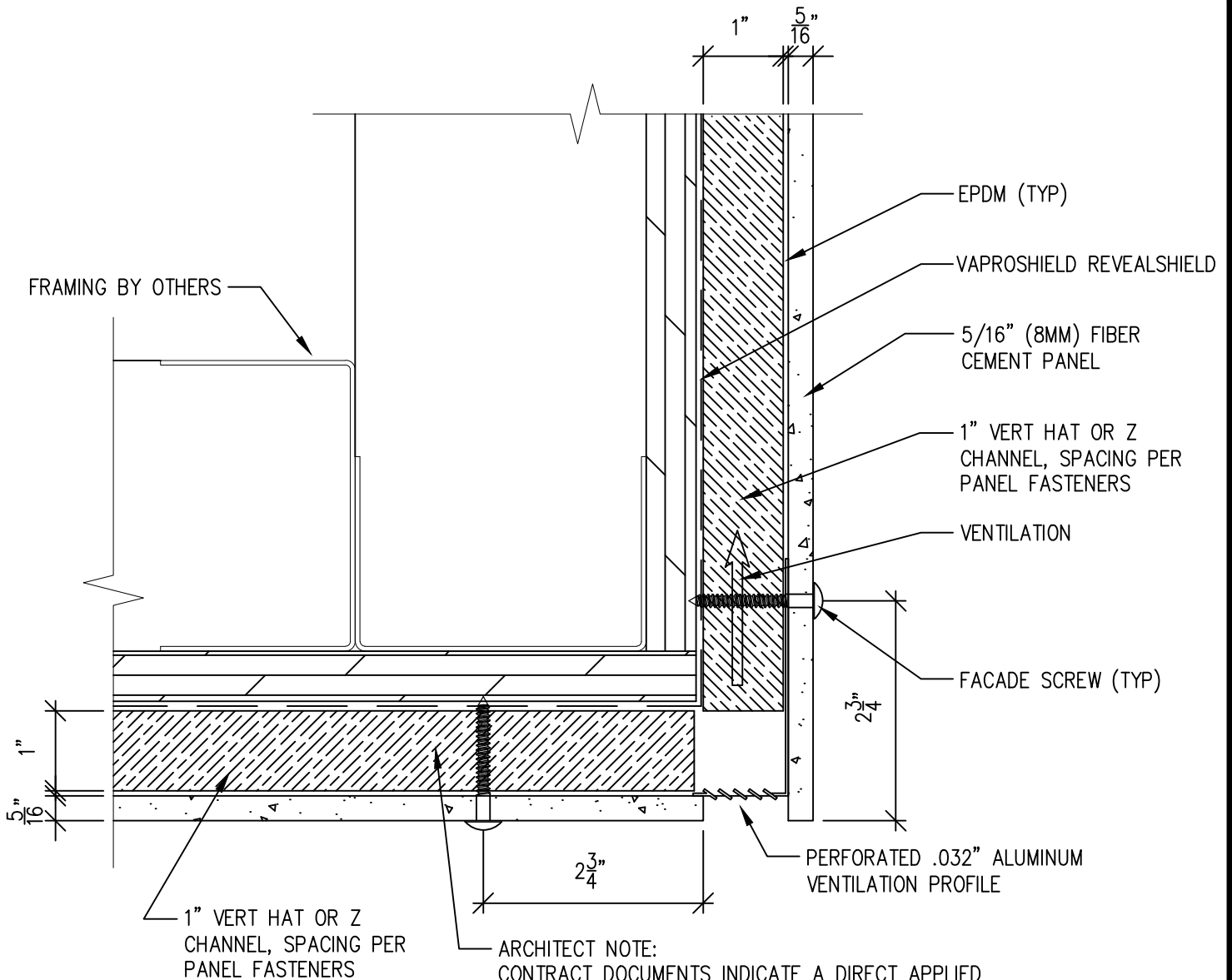

ARCHITECT NOTE:  
 CONTRACT DOCUMENTS INDICATE A DIRECT APPLIED APPLICATION OF FIBER CEMENT PANEL IN THIS LOCATION. THIS IS A NON-WARRANTED INSTALLATION APPLICATION. A MINIMUM  $\frac{3}{4}$ " VENTILATION SPACE IS NECESSARY DIRECTLY BEHIND THE FIBER CEMENT PANEL TO MAINTAIN WARRANTY.

NOTES:

1. PANEL VERTICAL AND HORIZONTAL JOINT SPACING SHOULD BE  $\frac{5}{16}$ " TYPICAL.
2. EPDM GASKET **MUST** BE INSTALLED CONTINUOUSLY ON ALL SUBFRAMING.

SCALE: 6"=1'-0"



KØL HIGH DENSITY  
 FIBRE CEMENT FACADE PANELS  
 KOLFACADE.COM

Ref.:  
 Typical Window  
 Jamb Detail

Date: 4/6/2019